

Montage-handleiding elektrokabelset voor
trekhaak met 12-N contactdoos
vlg. DIN/ISO norm 1724

Fitting instructions electric wiringkit
towbar with 12-N socket up to
DIN/ISO norm 1724

Einbauanleitung Elektrosatz
Anhängervorrichtung mit 12-N Steckdose
lt. DIN/ISO Norm 1724

Instructions de montage du faisceau
électrique pour crochet d'attelage
conforme à la norme DIN/ISO 1724
prise 12-N

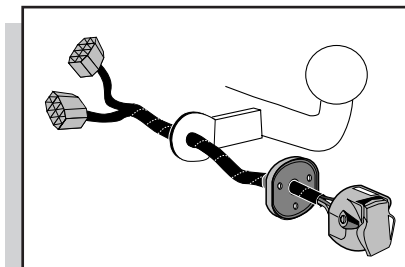

CITROËN XSARA PICASSO 1999-

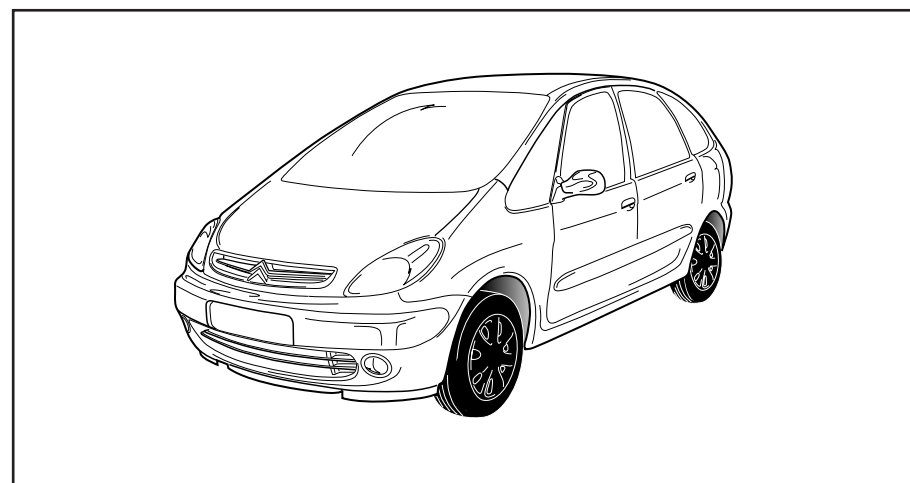

Bestel Nr.: CT-003-BB

* Teilliste

* Liste de pieces

* Part list

* Onderdelenlijst

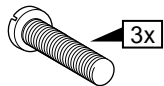
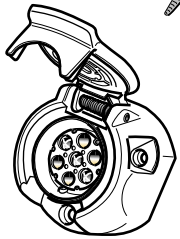
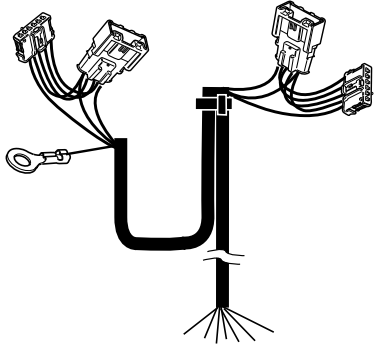
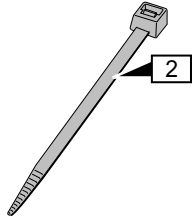
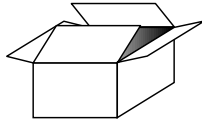

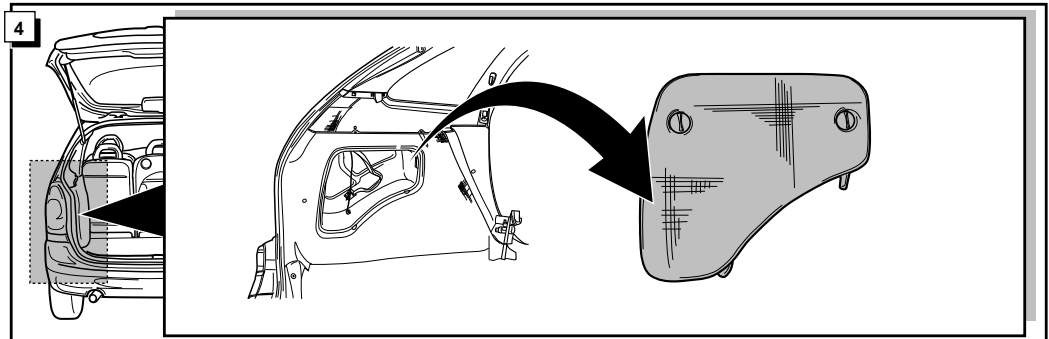
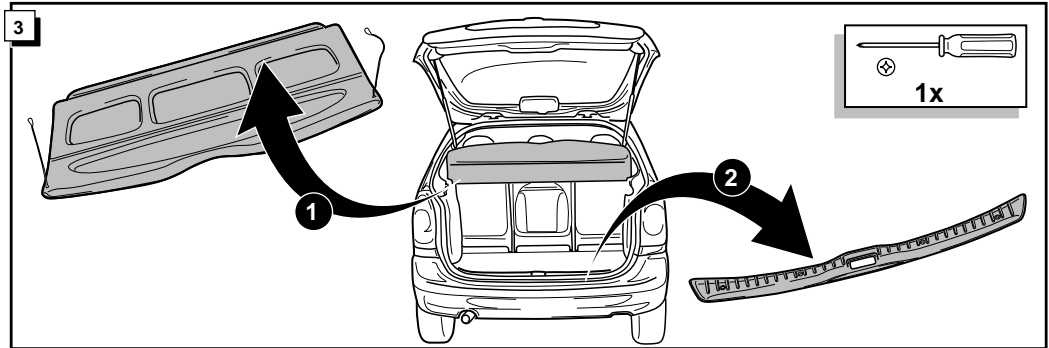
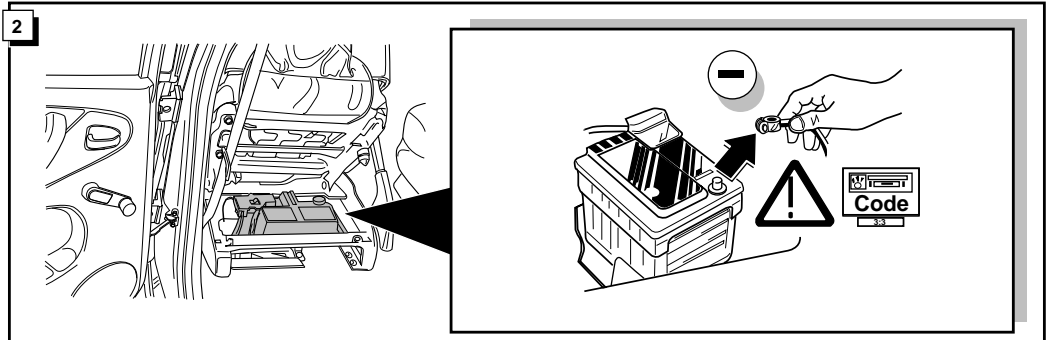
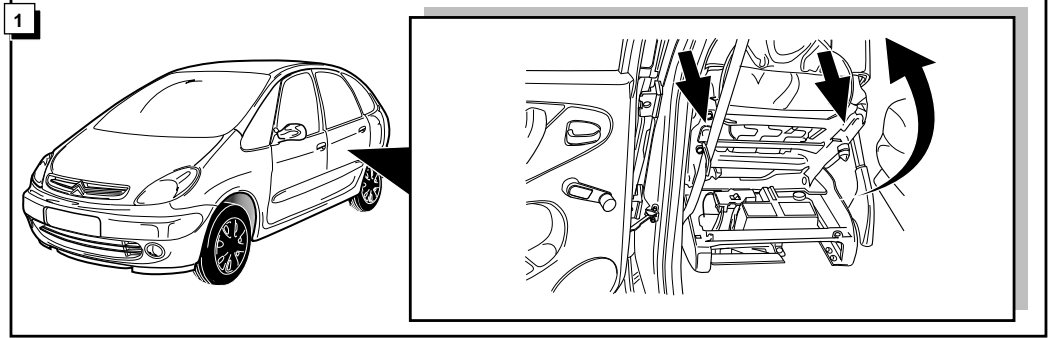

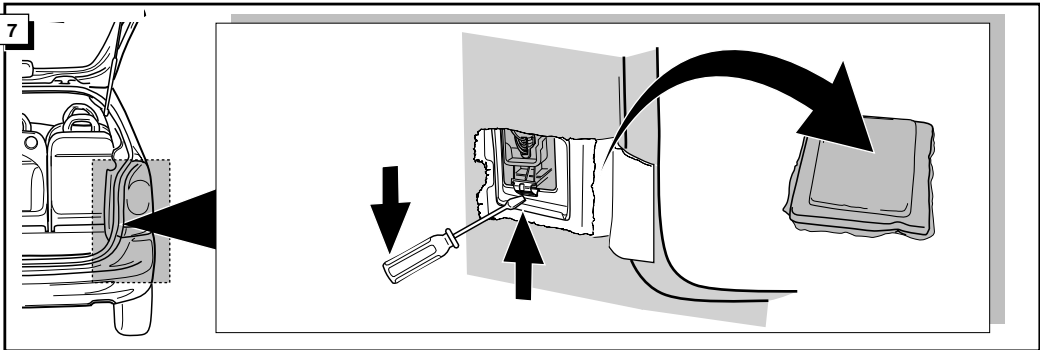
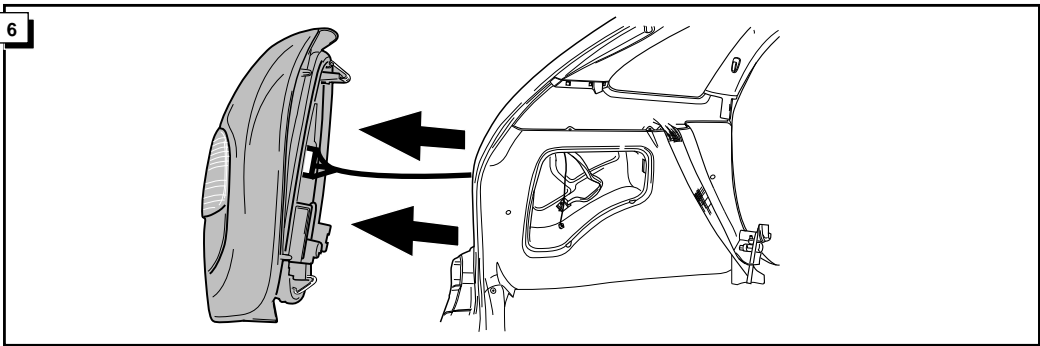
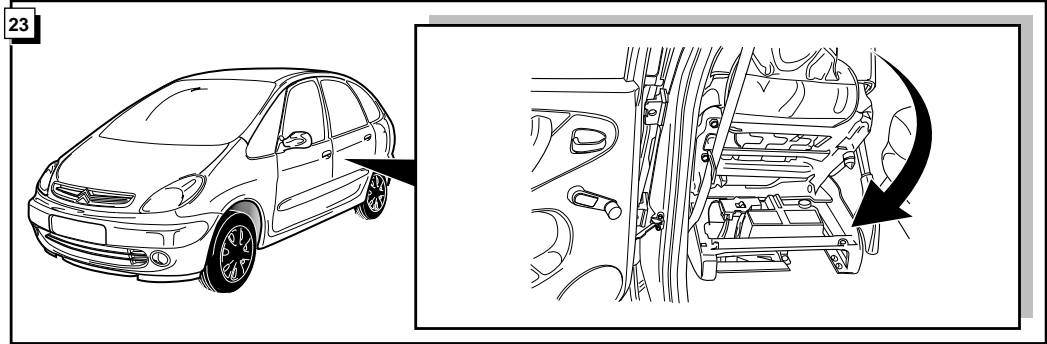
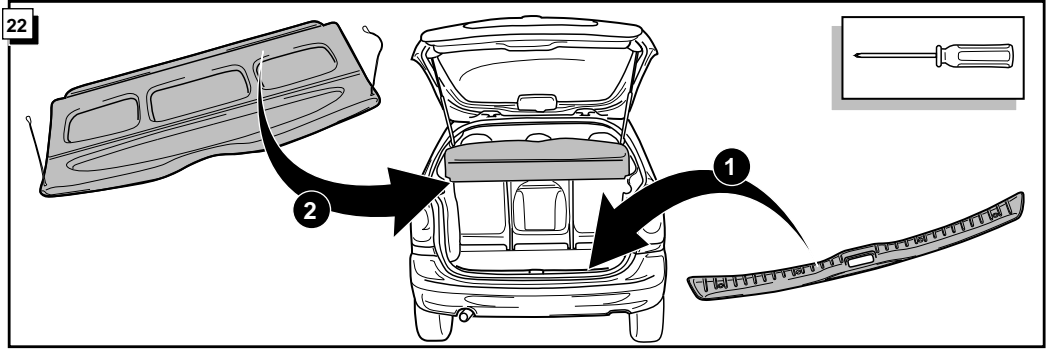
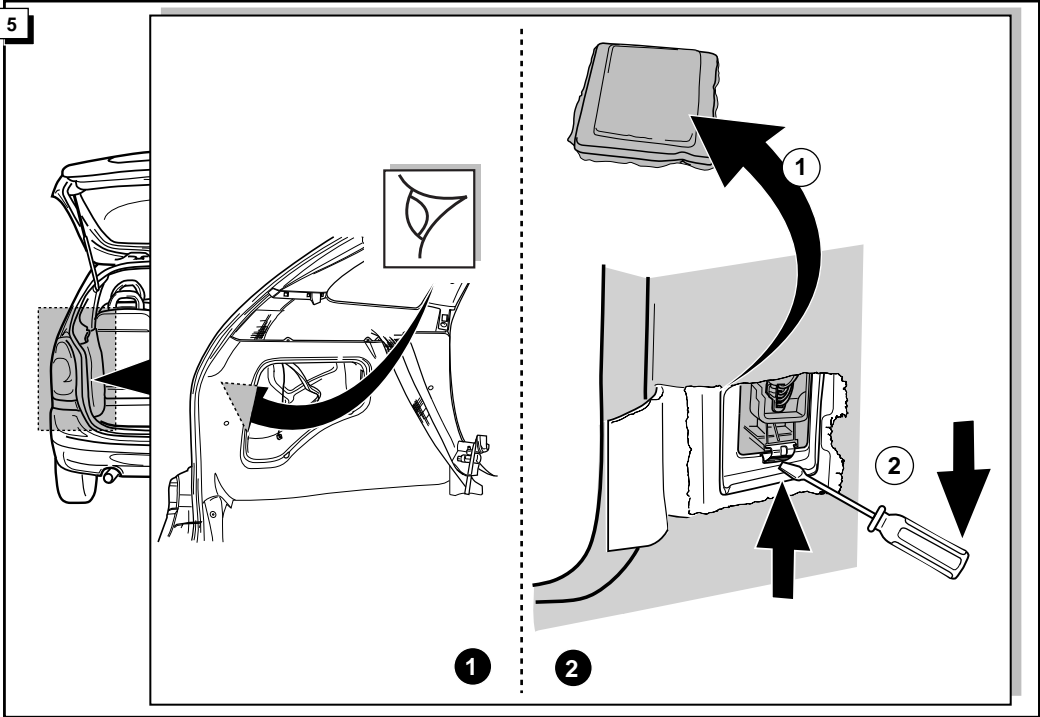

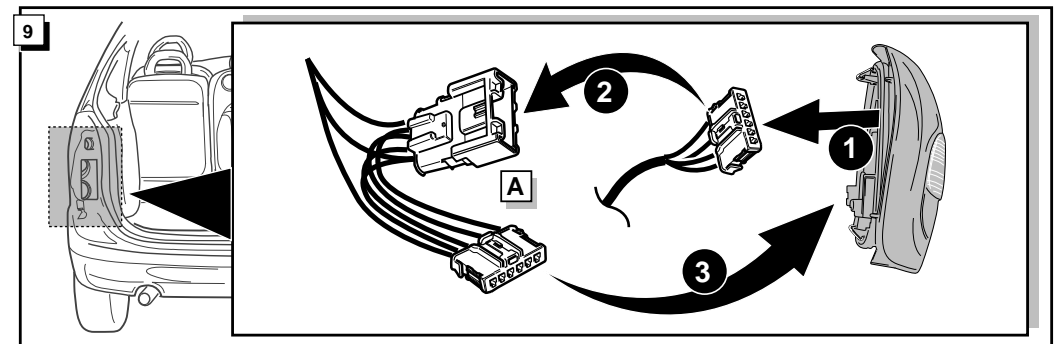
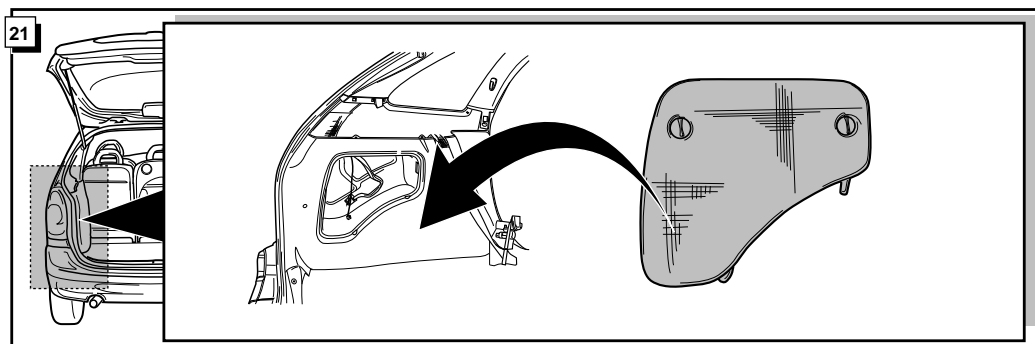
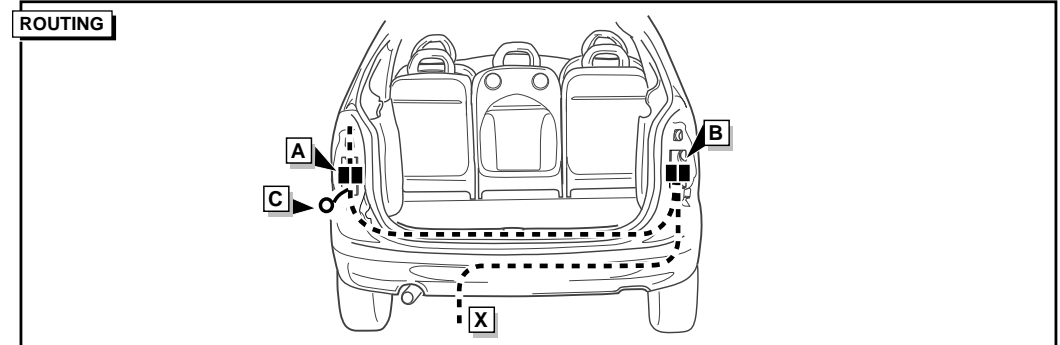
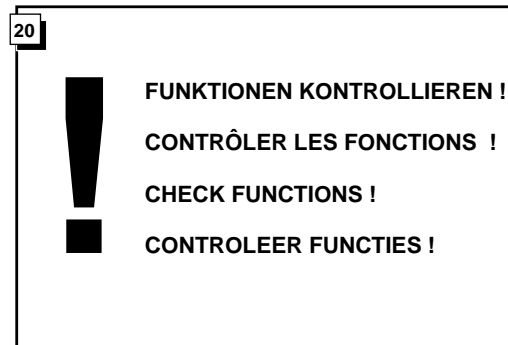
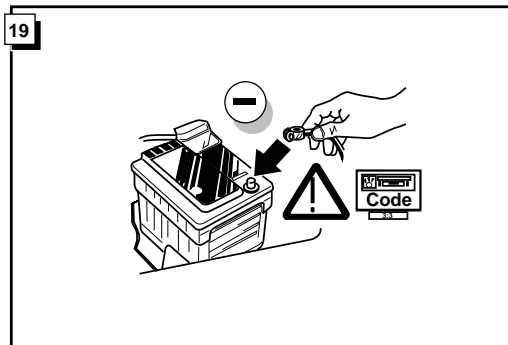
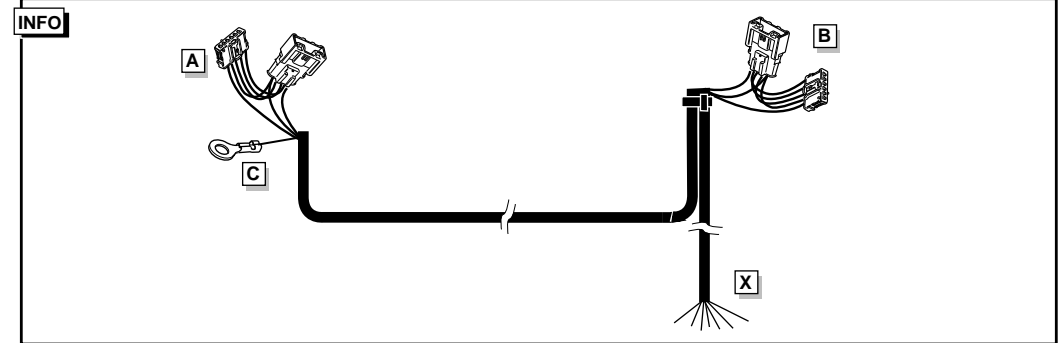
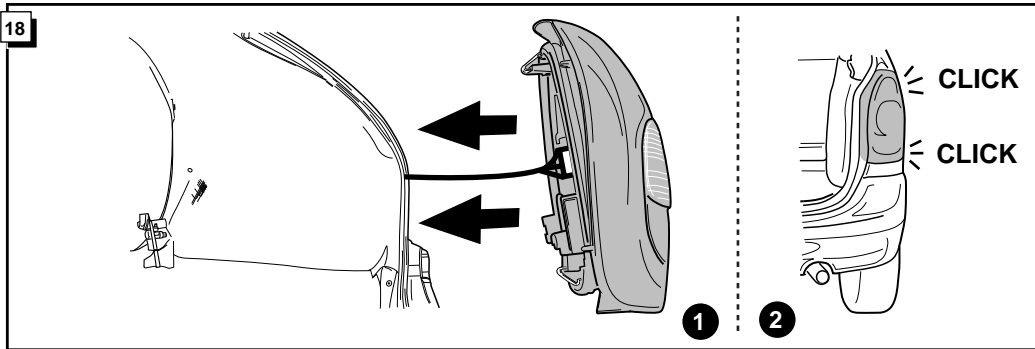
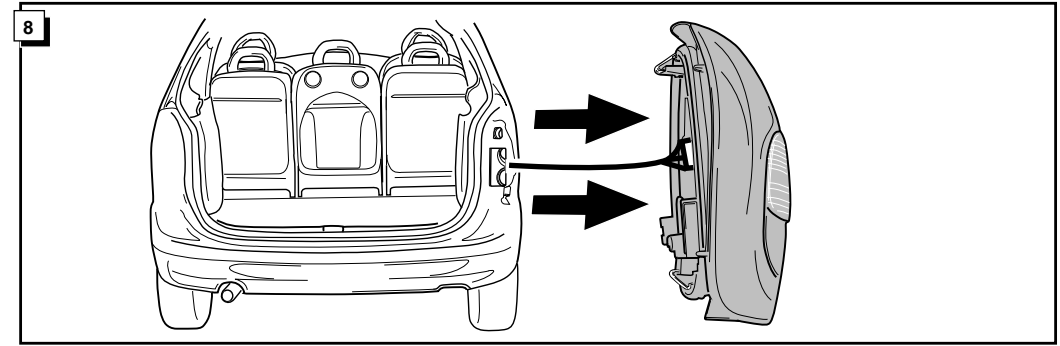
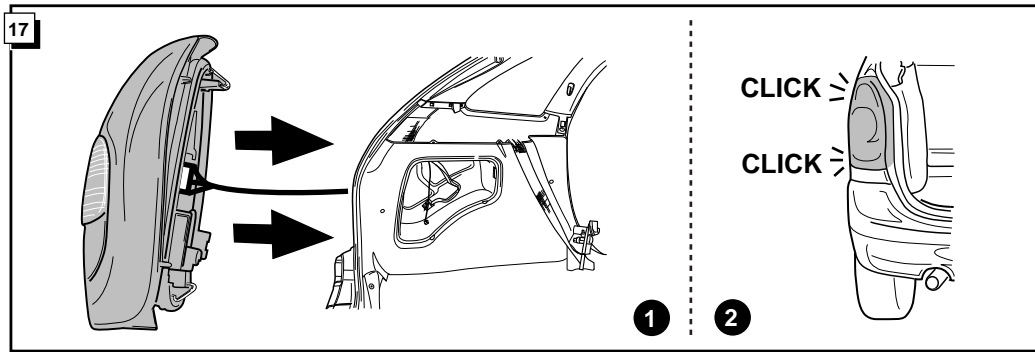

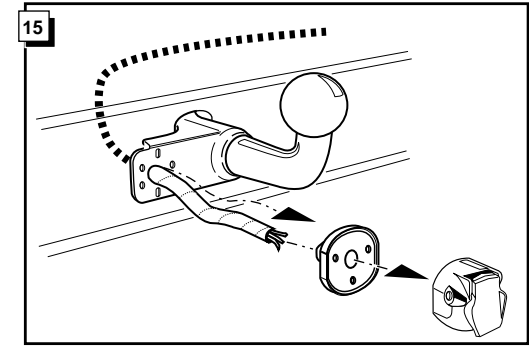
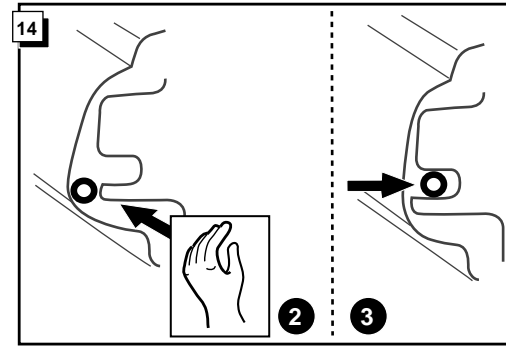
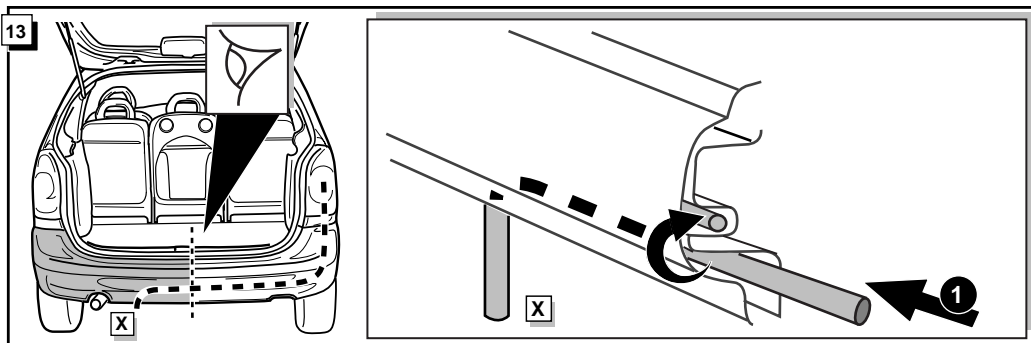
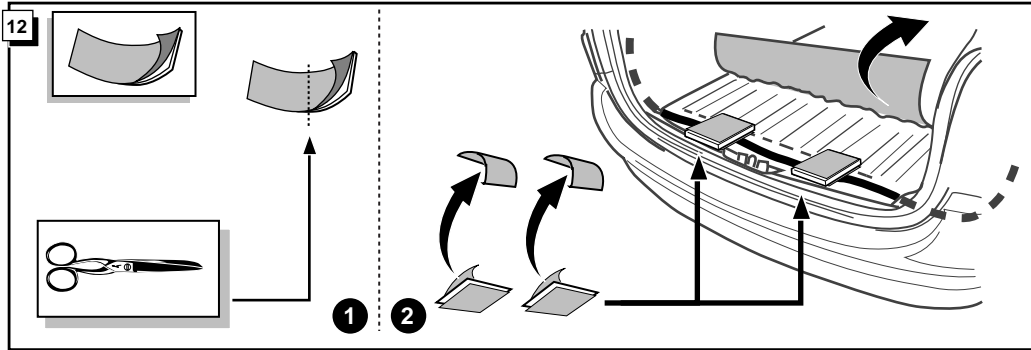
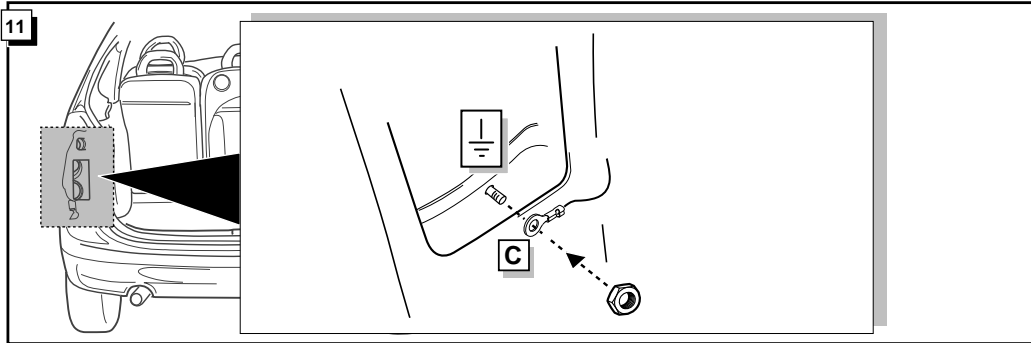
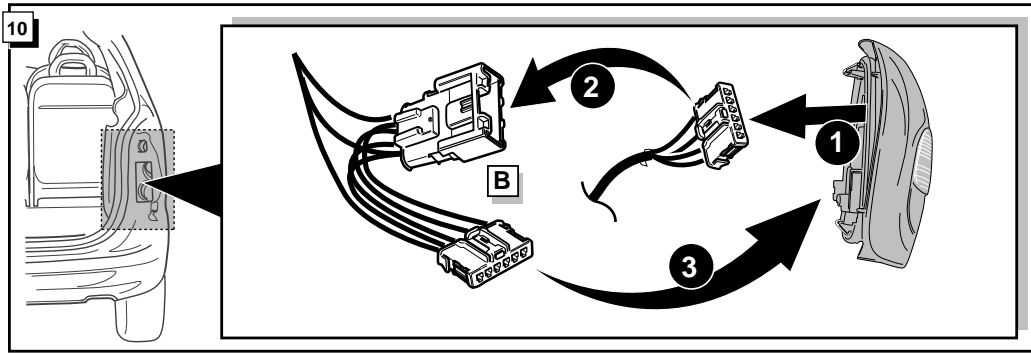

INFO Anschluß Steckdose / Connection de la prise / Socket connection / Contactdoos aansluiting

DIN/ISO 1724		D	F	GB	NL
↶	1/L	gelb	jaune	yellow	geel
↷	2	blau	bleu	blue	blauw
⎓ 1-8	3/31	weiß	blanc	white	wit
↶	4/R	grün	vert	green	groen
☀	5/58-R	braun	marron	brown	bruin
STOP	6/54	rot	rouge	red	rood
☀	7/58-L	schwarz	noir	black	zwart
⊕ ↷ ⊖ ↶	8/58-b	grau	gris	grey	grijs

